

Monitor Stand

User Guide

Branch

The new way of working you've been waiting for.

Scan here for a digital copy
of your assembly guide.



Caution

- The Monitor Stand should only be attached to a flat, solid, and stable Desk Surface. Never attempt to attach to surfaces that the Monitor Stands cannot fully clamp to. Always test the surface to be used before setting up the Monitor Stand
 - Do not change the specifications or modify this product for any other purpose beyond its intended use as a Monitor Stand.
 - Never sit or stand on the Monitor Stand
 - Do not place more than 40 lbs (18 kg) on the Medium and Large Monitor Stands
 - If any parts are missing, broken, damaged, or worn, stop use of the Monitor Stand until Branch Authorized replacement parts are received.
 - Be careful to ensure items fit firmly on the Monitor Stand Top surface, items on top of the stands are placed at your own risk.
 - The Monitor Stands can fit desks with an exposed top surface thickness of 0.75”-2.35”
 - Failure to follow these warnings may result in serious injury.
 - Keep this manual for future reference.
-
- If you are attaching your Monitor Stand on a Branch **Daily Desk**, please follow the Daily Desk Assembly Guide to remove the rear rail prior to attaching the Stand
 - If you are attaching your Monitor Stand to a Branch Desk with a **Cable Organizer** attached, you will need remove the Cable Organizer during the Monitor Stand attachment process, then re-install your Cable Organizer using the product Assembly Instructions

Weight Limits

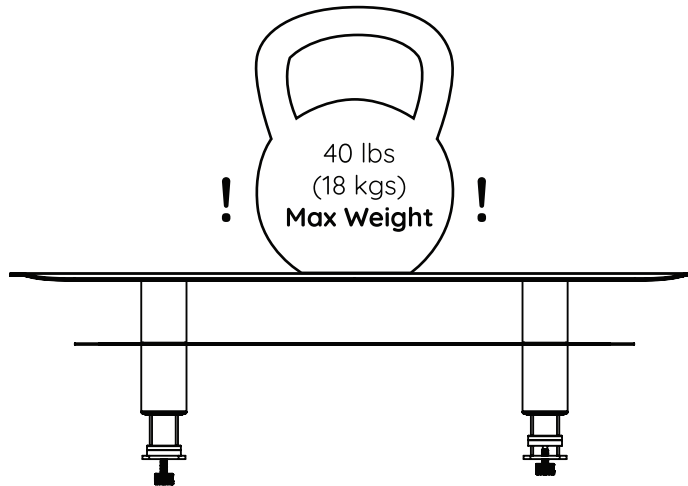

Monitor Stand
Small & Large

Components

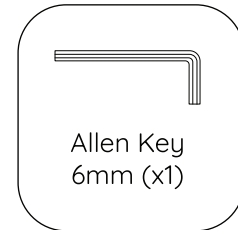
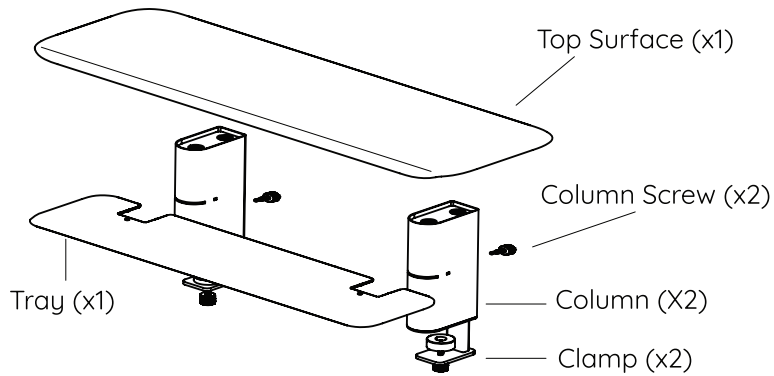

1

①

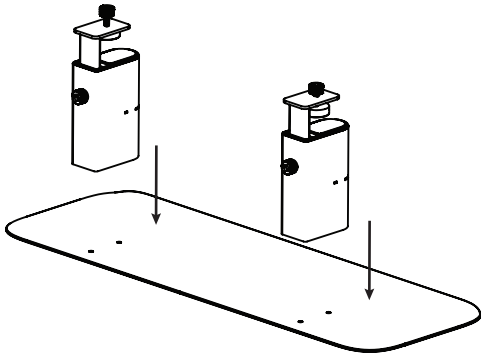

②

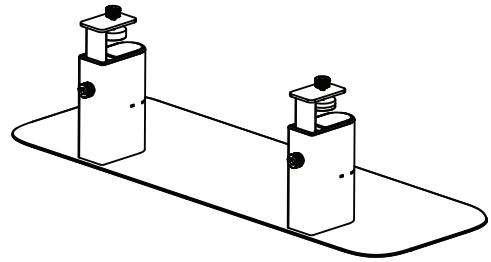

On a clean, flat surface, lay the **Top Surface** (x1), felt facing down. Align the **Columns** (x2) over the holes as shown and push to connect. The **Columns** should “snap” into position.

2

①

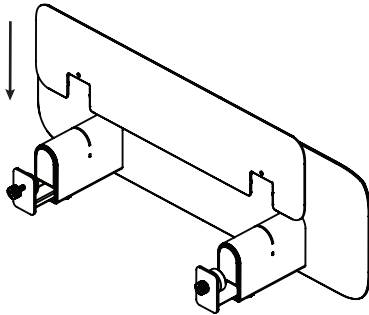

②

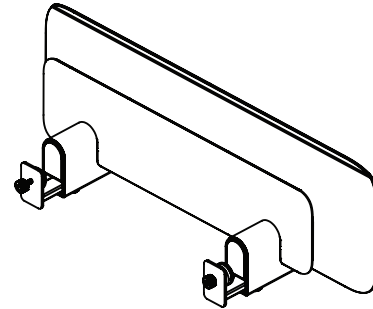

Carefully lay the assembled **Top Surface** and **Columns** onto its backside. Align the **Tray** into slits on the **Columns** and firmly insert. The **Tray** should “snap” into position.

3

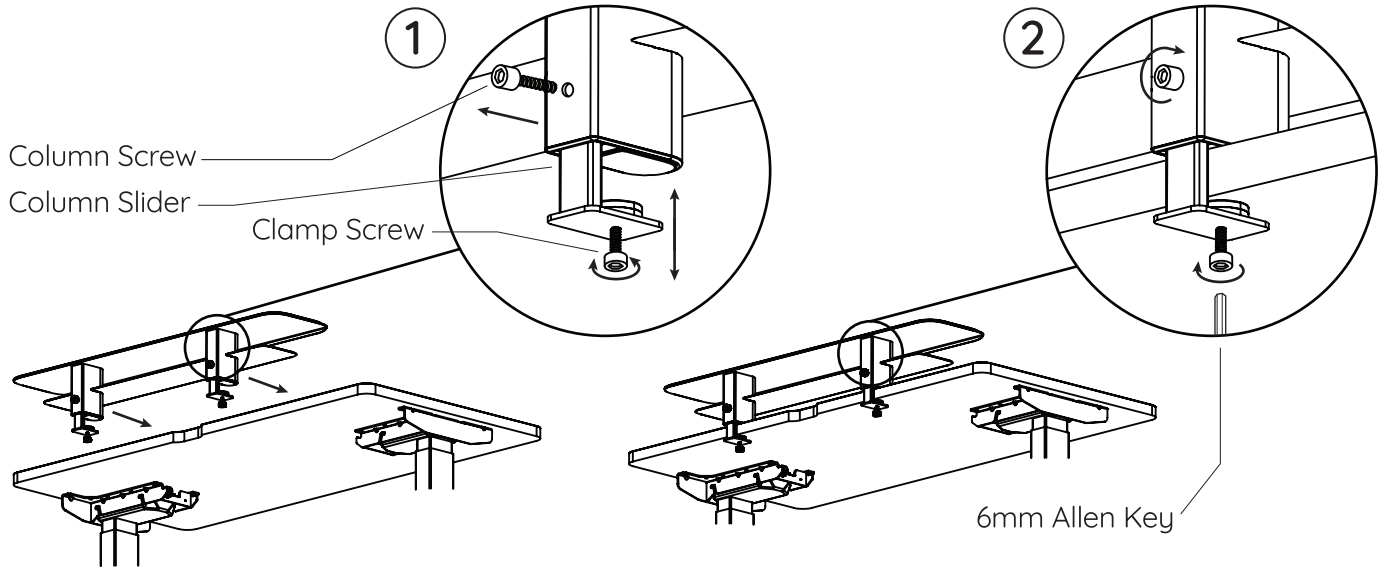

Remove the **Column Screw** (x1) and adjust the Column height to the position that closest matches your desktop's thickness. Securely tighten the **Column Screw** with the **6mm Allen Key**. Position the **Monitor Stand** onto your desk surface and securely tighten the **Clamp Screw** using the **6mm Allen Key**. Repeat for the second column.

The **Monitor Stand** can fit desks with an exposed top surface thickness of 0.75" - 2.35"

User Guide (suggested monitor sizes)

Small

Screens up to 27"

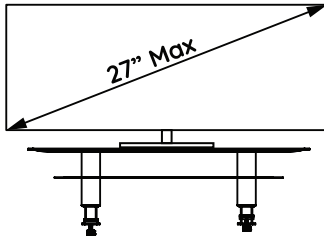

Large

2 Screens up to 24"

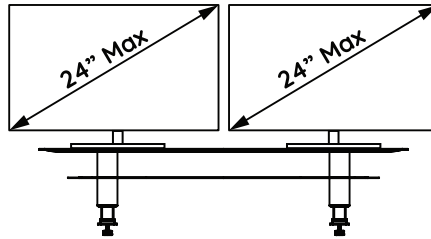

Large

Screens up to 39" (depending on base)

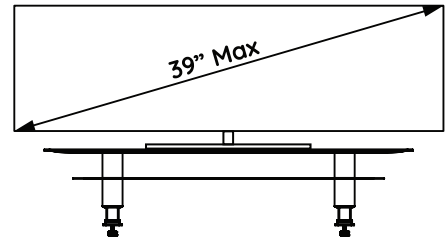

Top Surface Area

Note: Be careful to ensure monitor bases and other items fit firmly on the Monitor Stand Top surface, items on top of the stands are placed at your own risk.

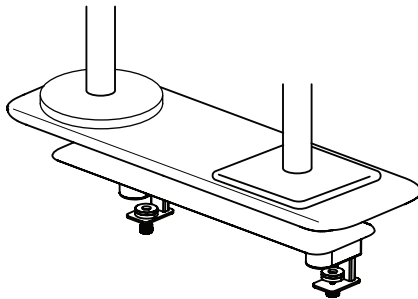

Firmly Fit

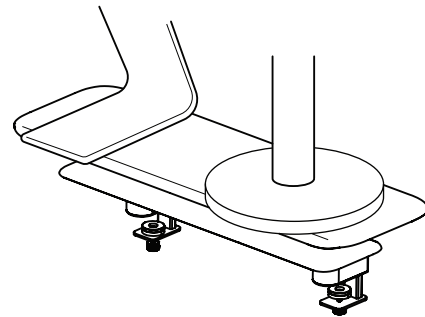

Overhanging Items

Contact

Have a question, comment, or suggestion?

hello@branchfurniture.com
branchfurniture.com

Branch